



"Siskin" Shoalbuster 2709

Lindtsedijk 10E
3336 LE Zwijndrecht
The Netherlands

T: +31 (0)78-6192507
E: chartering@hermansr.com



GENERAL

Yard no. : 571624 {Damen Shipyards
Hardinxveld}
Delivery date : June 2011
Type : Shoalbuster 2709
Basic functions : Towing, Anchor handling, Dredge
support, Supply, Survey, Windfarm
support
Classification : Bureau Veritas I 3/3 {E}Tug Unres.
Area
Nat. Authorities : Dutch Shipping Inspection continuous
service
Callsign : PCLJ
IMO No. : 9563201
MMSI No. : 246804000

Kg 5530	Kg 6780	Kg 8740	Kg 11860	Kg 16470
m 18.50	m 15.53	m 12.62	m 9.92	m 7.65

DIMENSIONS

Length : 27.02 m
Width : 9.10 m
Min draft : 2.40 m
Max draft : 2.70 m
GT/NT : 221 GT / 66 NT

TANK CAPACITIES

Fuel oil : 122.00 m³
Fresh water : 30.10 m³
Sewage : 2.20 m³
Dirty oil : 4.30 m³
Lub. oil : 3.90 m³
Hydraulic oil : 1.60 m³
Bilge Water : 4.30 m³

PERFORMANCES

Bollard pull : 40.0 ton (m)
Speed : 11.9 knots

PROPULSION SYSTEM

Main engines : 2 x Caterpillar 3512 B TA/A
Total power : 2238 kW (3000 bhp) at 1600 rpm
Gearboxes : 2 x Reintjes WAF 665 / 5.95:1
Propulsion : 2 x Promarin fixed pitch propellers
Diameter : 2 x 2100 mm v.d Giessen Optima
nozzles
Bowthruster : 1 x 200 bhp
Rudders : 2 x Fishtail rudders, 45 degrees

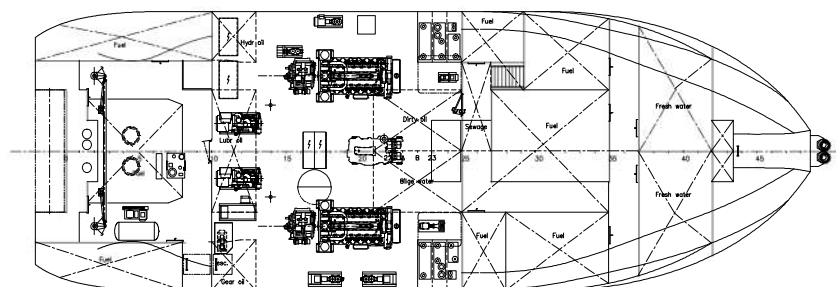
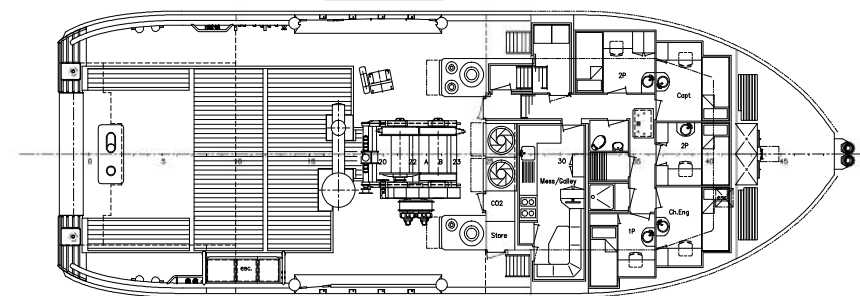
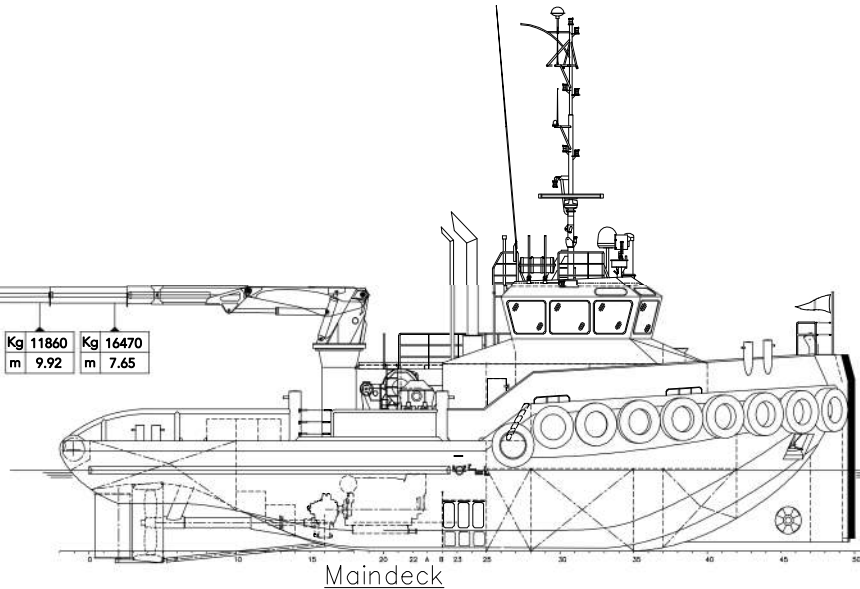



"Siskin" Shoalbuster 2709

Lindtsedijk 10E
3336 LE Zwijndrecht
The Netherlands

T: +31 (0)78-6192507
E: chartering@hermansr.com

AUXILIARY EQUIPMENT

- Generator sets : 2 x Cat C-4.4 TA 86.3 kVA, 50 Hz 230/400V
- Hydraulic set : 1 x Caterpillar C-09 TA
- Fuel separator : Alfa Laval Mib 303
- Compressors : 1 x ABAC 150 ltr/min
1x Alup SCK 9-8 @ 1200L/min
- Transfer pumps : For water and fuel : SIHI 32 m³/hr at 3.5 bar

DECK LAYOUT

- Anchors : 2 x 225 kg Pool 110 m shortlink 22 mm chain
- Chain : 192,5 m shortlink 17.5 mm chain
- Anchor winch : Ridderinkhof , hydraulic
- Deck crane : HS Marine AKC 185-18.5 E4, 16,47T @ 7,65m
- Towing winch : Ridderinkhof 75 ton / min Holding 100 ton
- Anchor handling : Ridderinkhof 40 ton
- Capacity : 700 meter for towing 400meter
- Towing pins : 3 x Hydraulic tow / anchorhandling pins
- Tugger winch : Brevini, 8 ton (m) @ 9m/min
- Maximum deckload : 10 ton /m²
- Free deck space : 47 m²
- A-frame : 25-30T SWL
- Plough : Available
- Container capacity : 2x 20"

ACCOMODATION

Heated and airconditioned living spaces for seven persons, consisting of a captain's cabin , a C.E. cabin , one single crew cabin, two double crew cabins, a galley and sanitary facilities.

NAUTICAL AND COMMUNICATION EQUIPMENT

- According GMDSS : Area A3
- Searchlights : 2 x Pesch 1000 W
- Magnetic compass : 1 x Cassens & Plath Reflecta 1
- Gyro compass : 1 x Anschuetz STD 22 Compact
- Radar system : 1 x Furuno FR-2117B
- AIS : 1 x Furuno FA 150
- D-GPS : 1 x Furuno GP-150
- Plotter : 1 x Tresco ECDIS
- Gyrocompass : 1 x Raytheon Anschutz STD 22
- Autopilot : 1 x RH Sea/river pilot 75
- Echosounder : 1 x Furuno FE 700
- Handheld VHF : 2 x Jotron TRON TR20
- Watch alarm : 1 x Marble 421
- VHF radio telephone : 2 x sailor 5022 with DSC + 1 x sailor 4800
- Navtex : 1 x Furuno NX 700
- SSB/DSC : 1 x Furuno, type FS-1570
- Communication : 2 x Inmarsat C, Satellite telephone, GSM
- V-SAT : 1x Intellian V80G
- CCTV : 1 x Orlaco

Crane with fixed hook

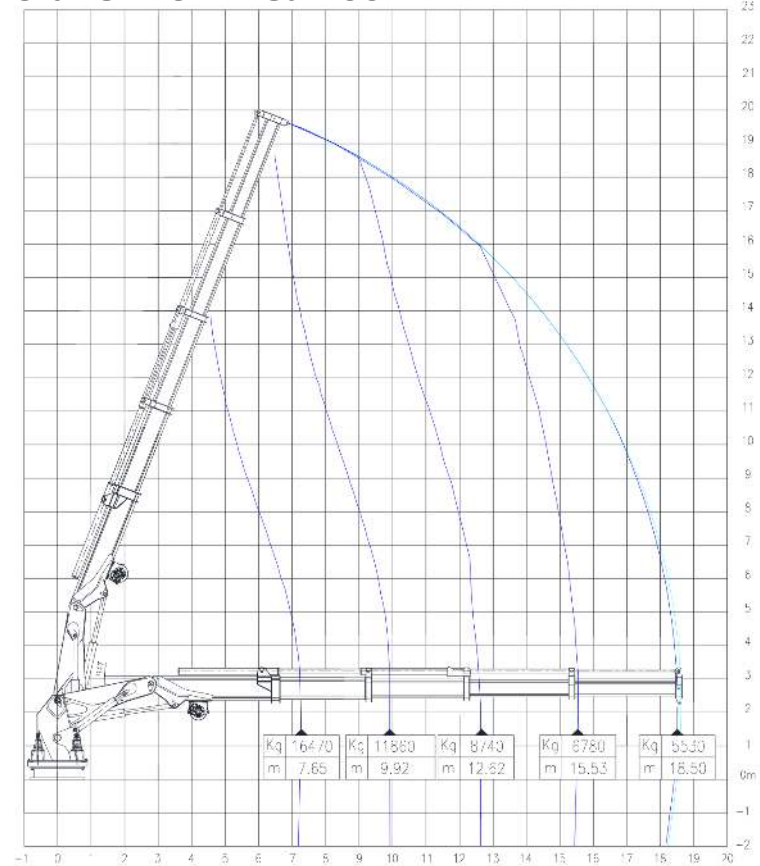

Crane with winch wire

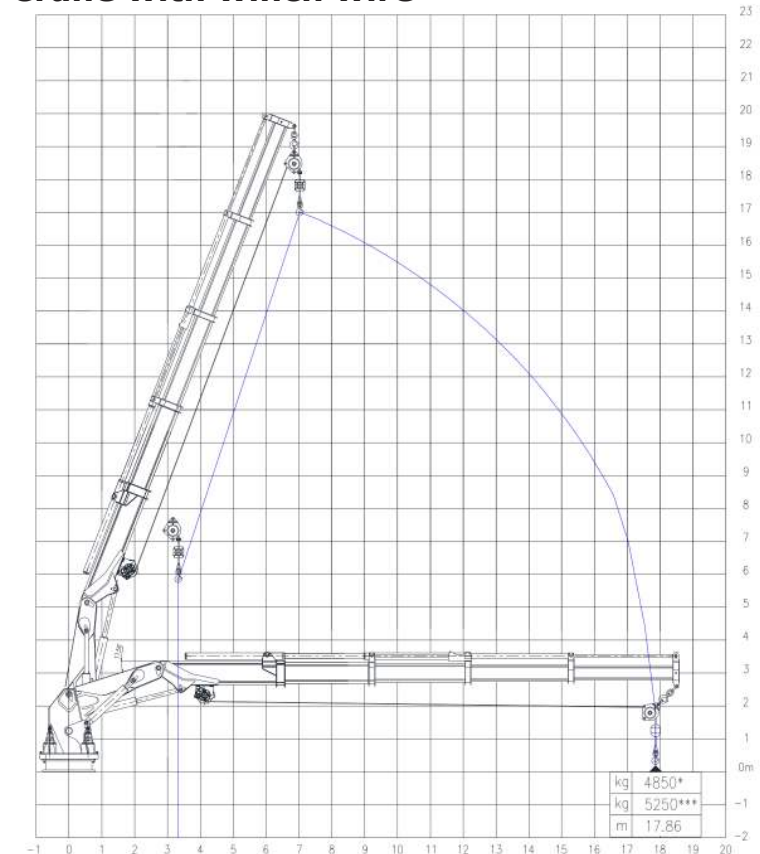

For more information about chartering please contact us
Telephone: +31 (0)78 619 25 07 - Email: chartering@hermansr.com