



# "Odin" Multicat 3013

Ebweg 56  
2991 LT Barendrecht  
The Netherlands  
T: +31 (0)78-6192507  
E: chartering@hermansr.com  
I: www.hermansr.com



## GENERAL

Yard no. : Damen Shipyards 571630  
 Delivery date : June 2010  
 Type : Multicat 3013  
 Basic functions : Towing, Anchor handling, Dredge support, Supply, Survey, Wind farm support  
 Classification : Bureau Veritas I \* Tug Unrestricted navigation \* MACH, AUT-UMS  
 Nat. Authorities : Dutch Shipping Inspection Unrestricted service  
 Callsign : PCCQ  
 IMO No. : 9572824  
 MMSI No. : 245307000

## DIMENSIONS

Length O.A : 29.90 m  
 Width O.A : 13.50 m  
 Min draft : 2.40 m  
 Max draft : 2.60 m  
 GT/ NT : 341 GT/ 102 NT

## TANK CAPACITIES

Fuel oil : 205.0 m<sup>3</sup>  
 Fresh water : 55.0 m<sup>3</sup>  
 Sewage : 5.9 m<sup>3</sup>  
 Dirty oil : 2.8 m<sup>3</sup>  
 Lub. oil : 2.8 m<sup>3</sup>  
 Hydraulic oil : 4.5 m<sup>3</sup>  
 Bilge water : 2.8 m<sup>3</sup>

## PERFORMANCES

Bollard pull : 35 ton (m)  
 Speed : 10.6 knots

## PROPULSION SYSTEM

Main engines : 3x Caterpillar 3412D TTA  
 Total power : 1896 kW (2550 bhp) at 1800 rpm  
 Gear boxes : 3x Reintjes WAF 464 5.591:1  
 Propulsion : 3x Promarin fixed propellers in Optima nozzles  
 Diameter props : 1700 mm  
 Bow thruster : Hydraulic driven 200 kW (272 bhp) 360°  
 Rudders : 3x Fishtail rudders

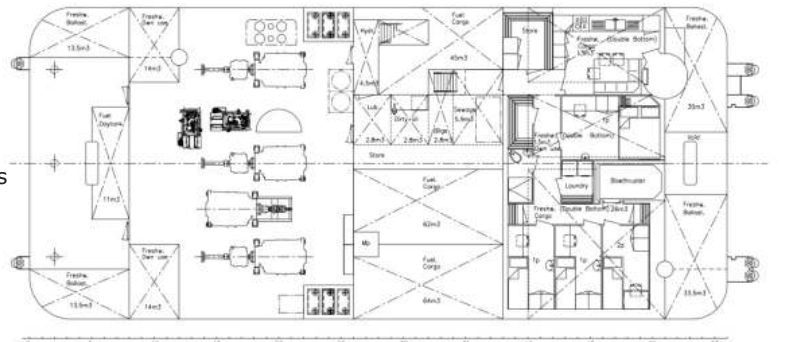
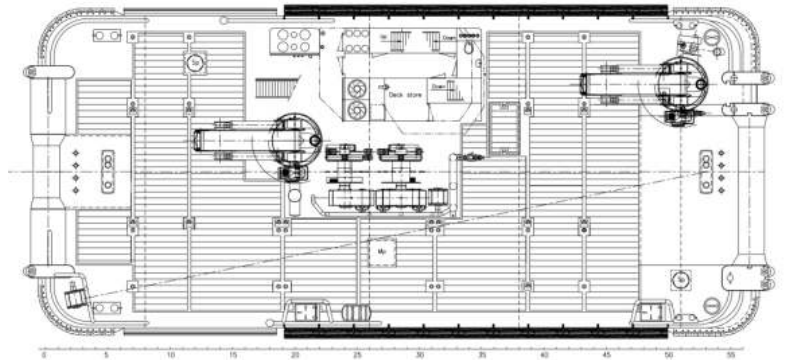
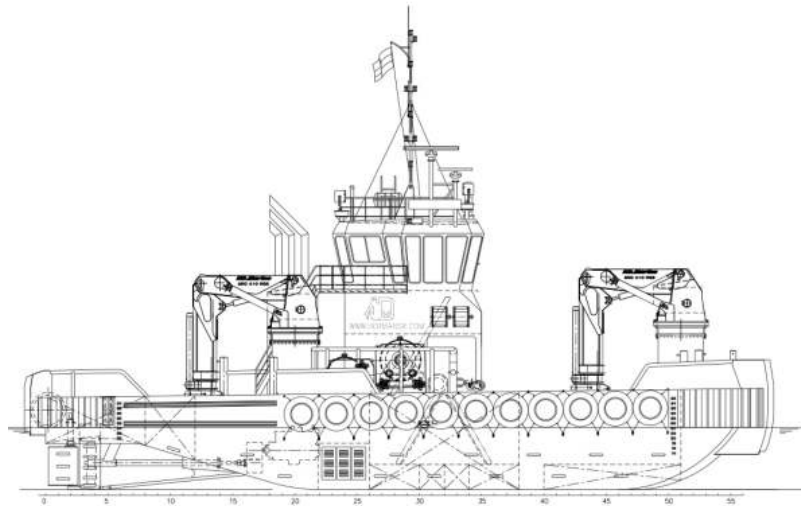



# "Odin" Multicat 3013

Ebweg 56  
2991 LT Barendrecht  
The Netherlands  
T: +31 (0)78-6192507  
E: chartering@hermansr.com  
I: www.hermansr.com

## AUXILIARY EQUIPMENT

Generator sets : 2x Caterpillar C4.4, 107,5 kVA each  
Hydraulic power : Caterpillar 3412D TTA, 632 kW  
Fuel oil separator : Alfa Laval MIB 303  
Air compressor : Alup SCK 30-10 scr

## DECK LAYOUT

Anchor : 1x 360 kg Pool TW (HHP) + 1x spare  
Chain : 19mm stud-link anchor chain 275m  
Anchor winch : Ridderinkhof, hydraulic driver  
Deck cranes : 2x HS Marine AKC 410 HE2  
36.85 ton @ 8.42m & 22.8 ton @13.10m  
Anchor handling winch: Kraaijeveld KA-30/2-H-TR  
Capacity : 100 ton at 8m/min pulling force (1<sup>st</sup> layer)  
50 ton at 12 m/min pulling force (1<sup>st</sup> layer)  
20 ton at 32 m/min pulling force (1<sup>st</sup> layer)  
150 ton brake holding force (1<sup>st</sup> layer)  
Towing winch : Kraaijeveld KA-20/2-H-TR  
Capacity : 40 ton at 12m/min pulling force (1<sup>st</sup> layer)  
20 ton at 24 m/min pulling force (1<sup>st</sup> layer)  
100 ton brake holding force (1<sup>st</sup> layer)  
Towing hook : 2x Mampaey 20 ton SWL  
Tugger winches : 2x Dromec 12 ton at 4.5 m/min  
Free deck space : 180 m<sup>2</sup>  
Maximum deck-load : 15 ton/m<sup>2</sup>  
Container capacity : 5x 20" + 2x 10" in one time  
Towing pins : Fore WK hydraulics triple pins in a row type  
Aft WK hydraulics triple pin type

## ACCOMMODATION

Heated and air conditioned living spaces for six persons, consisting of a captain's cabin, one single crew cabin, two double crew cabins, a galley and sanitary facilities.

## NAUTICAL AND COMMUNICATION EQUIPMENT

According GMDSS : A3  
Search lights : 2x Pesch 2000 W  
Radar system : 1x Furuno, FAR 2117  
Compass : 1x Cassens & Plat, Reflecta 1  
Gyro compass : 1x Tokimec, ES-160  
Echo sounder : 1x Furuno, FE-700  
Speed log : 1x Furuno, DS-80  
GPS : 1x Furuno, GP-150D  
Chart system : 1x Transas NS 4000  
Autopilot : 1x Sea pilot 75  
VHF : 2x Sailor, RT5022  
Handheld VHF : 2x TR-20  
SSB : 1x Thrane & Thrane 5000  
Inmarsat-C : 2x Sailor, H-2095 C  
Navtex : 1x Furuno, NX-700  
Iridium telephone : 1x Sailor, SC 4000A  
GSM Telephone : 1x Sagem, RT 3000  
AIS : 1x Furuno, FA-150  
Watch Alarm : 1x Marble, 421  
Intercom : Sigma-700  
TV Satellite : 1x Seatel, Coastal 24

## Crane Forward AKC 410 HE-2

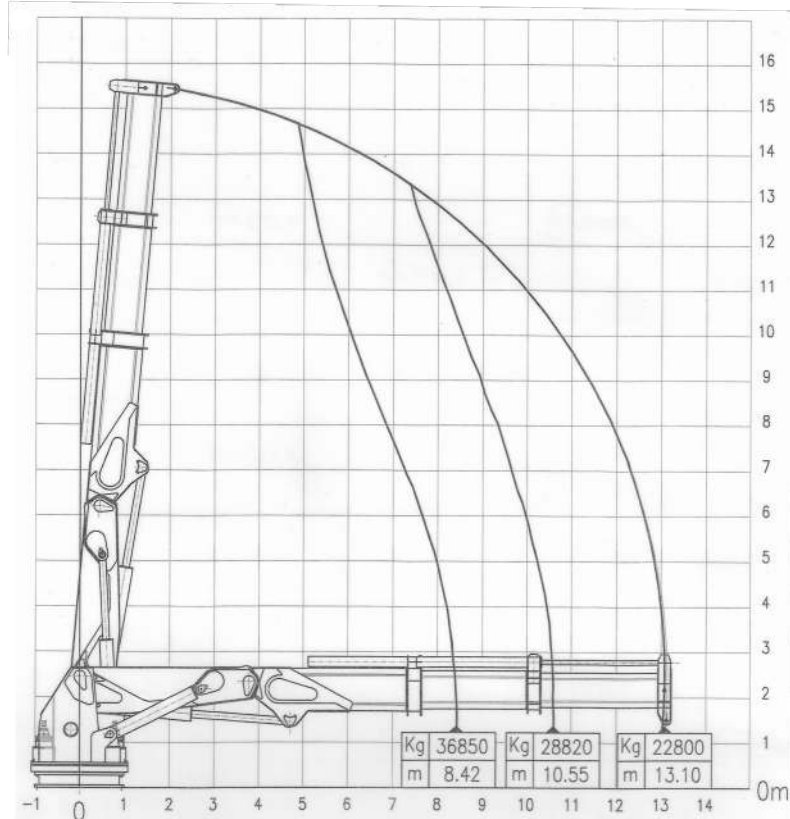

## Crane Aft AKC 410 HE-2

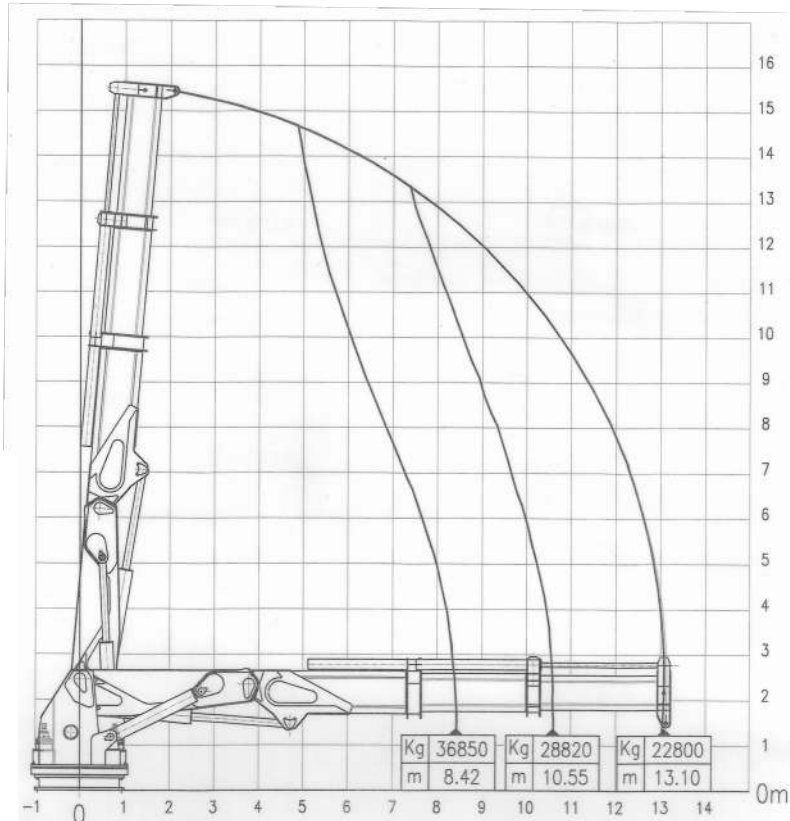

For more information about chartering please contact us  
Telephone: +31 (0)78 619 25 07 - Email: chartering@hermansr.com