



"Bella" Multicat 3313

Ebweg 56
2991 LT Barendrecht
The Netherlands
T: +31 (0)78-6192507
E: chartering@hermansr.com
I: www.hermansr.com



GENERAL

Delivery date : 2023
Type : Multicat 3313
Basic functions : Towing, Anchor handling, Dredge support, Supply, Survey, Wind farm support
Classification : Bureau Veritas I * Tug Unrestricted navigation * MACH, Offshore support vessel AUT-UMS
Nat. Authorities : Dutch Shipping Inspection Unrestricted service
Callsign : t.b.a
IMO No. : t.b.a
MMSI No. : t.b.a

DIMENSIONS

Length : 32.80 m
Width : 12.50 m
Min draft : 1.85 m
Max draft : 2.20 m
GT/ NT : 345 GT/t.b.a NT

TANK CAPACITIES

Fuel oil : 120.0 m³
Fresh water : 40.0 m³
Sewage : 12.0 m³
Dirty oil : 3.8 m³
Lub. oil : 2.4 m³
Hydraulic oil : 4.0 m³
Bilge water : 3.8 m³
Technical water : 80.0 m³

PERFORMANCES

Bollard pull : 30 ton (m) (estimated)
Speed : 10.8 knots (estimate)

PROPULSION SYSTEM

Main engines : 3x Caterpillar C18 TTA ACERT
Total power : 1797 kW (2409 bhp) at 2000 rpm
Gear boxes : 3x Reintjes WAF 364L 5.435:1
Propulsion : 3x Promarin fixed propellers in Optima nozzles
Diameter props : 1600 mm
Bow thruster : Hydraulic driven 294 kW (400 bhp)
Rudders : 3x Fishtail rudders

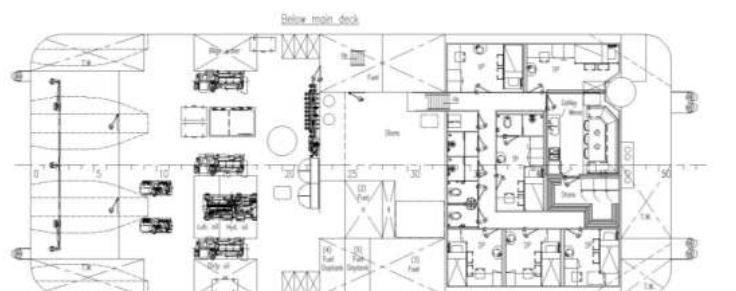
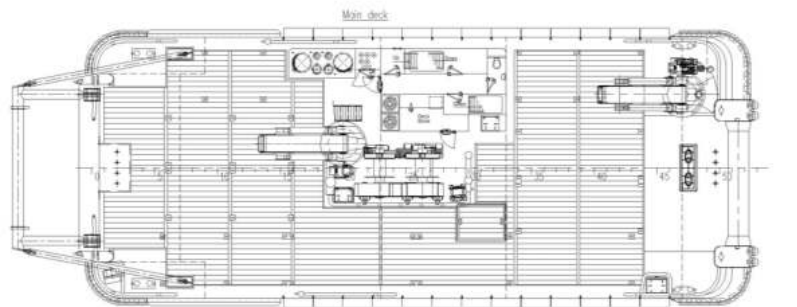
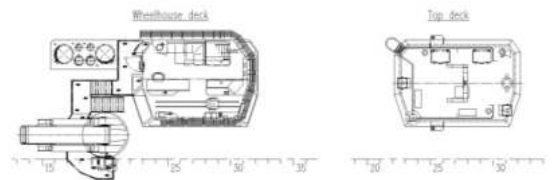
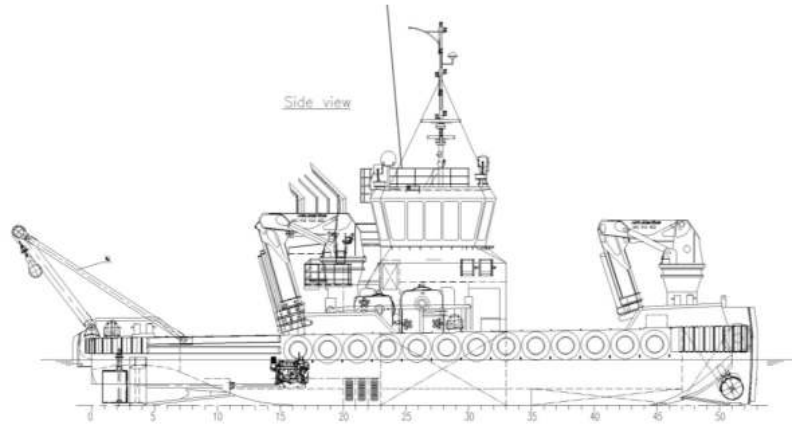



"Bella" Multicat 3313

Ebweg 56
2991 LT Barendrecht
The Netherlands
T: +31 (0)78-6192507
E: chartering@hermansr.com
I: www.hermansr.com

AUXILIARY EQUIPMENT

- Generator sets : 2x Caterpillar C4.4, 86 eKW
- Hydraulic power : 1x C18 TTA
- Fuel oil separator : Alfa Laval MIB 303
- Air compressor : Alup SCK 30-10 , 3.1 m³/min at 10 bar

DECK LAYOUT

- Anchor : 1x 400 kg Pool TW (HHP) + 1x spare
- Chain : 19mm stud-link anchor chain 275m
- Anchor winch : Ridderinkhof, hydraulic driver
- Deck cranes : 2x HS Marine AKC 410 18 HE3
49.1 ton @ 5.74m & 13.5 ton @18.00m
- Anchor handling winch: Kraaijeveld KA-30/2-H-TR
- Capacity : 100 ton at 8m/min pulling force (1st layer)
20 ton at 32 m/min pulling force (1st layer)
150 ton brake holding force (1st layer)
- Towing winch : Kraaijeveld KA-20/2-H-TR
- Capacity : 40 ton at 12m/min pulling force (1st layer)
12 ton at 24 m/min pulling force (1st layer)
100 ton brake holding force (1st layer)
- Towing hook : 1x Mampaey 25 ton SWL
- Tugger winches : 2x Dromec 12 ton at 4.5 m/min
- Free deck space : 200 m²
- Maximum deck-load : 8 ton/m²
- Container capacity : 9x 20" + 1x 10" in one time
- Towing pins : Fore WK hydraulics four pins in a row type

ACCOMMODATION

Heated and air conditioned living spaces for nine persons, consisting of a captain's cabin, two single crew cabin, three double crew cabins, a galley and sanitary facilities.

NAUTICAL AND COMMUNICATION EQUIPMENT

- According GMDSS : Area A3
- Search lights : 2x Pesch 2000 W
- Radar system : 2x Furuno, FAR 1518BB
- Compass : 1x Cassens & Plat, Reflecta 1
- Gyro compass : 1x Anschutz, standard 22
- Echo sounder : 1x Furuno, FE-800
- Speed log : 1x Skipper EML-224
- GPS : 1x Furuno, GP-170D
- ECDIS : 2x Furuno FMD 3100
- Autopilot : 1x SSimrad, AP 70
- VHF : 2x Thrane & Thrane, RT6222
- Handheld VHF : 2x Jotron TR-30
- SSB : 1x Sailor 6310
- Inmarsat-C : 2x Sailor 6110
- Navtex : 1x Furuno, NX-700A
- AIS : 1x Furuno, FA-170
- Watch Alarm : 1x Furuno BR-500
- Intercom : 1x Phonotech, CIS3101
- TV Satellite : 1x Cobham, Sea tel 80 TV
- V-SAT : 1x Cobham, sailor 800
- Wind indicator : 1x Obsemat, OMC 115

Crane aft

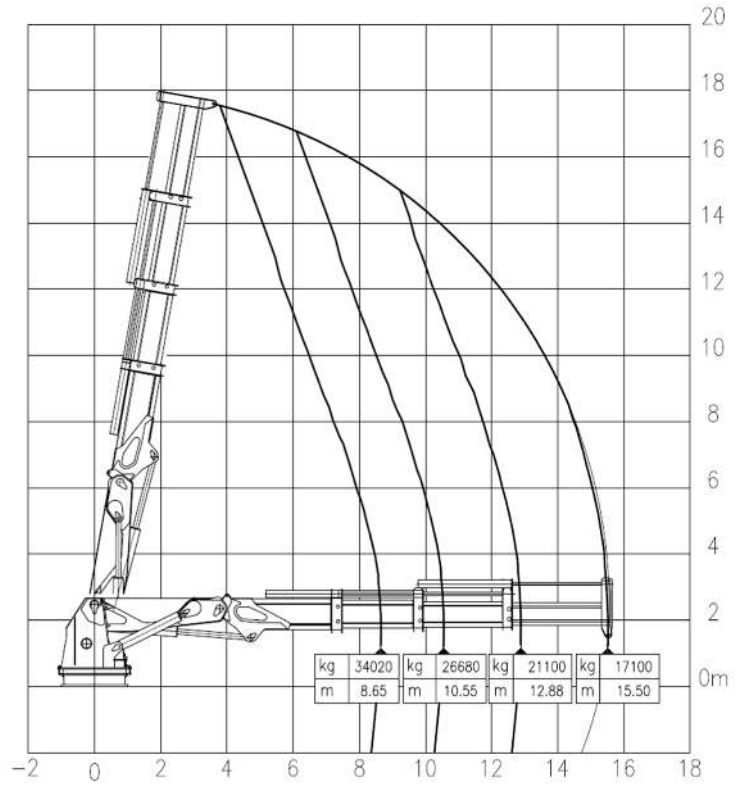

Crane forward

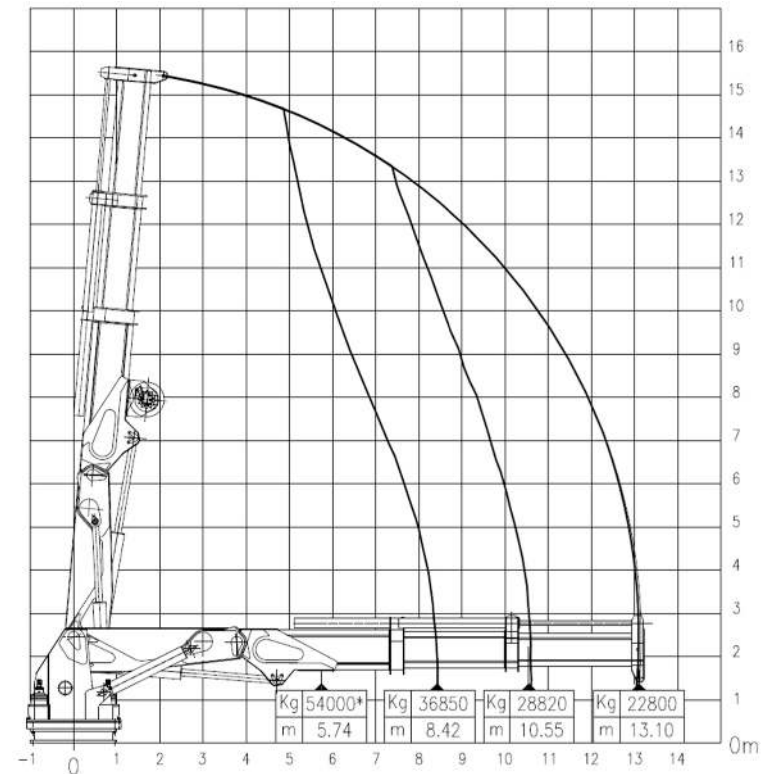

For more information about chartering please contact us
Telephone: +31 (0)78 619 25 07 - Email: chartering@hermansr.com